

Installation and Operating Instructions for Brake Caliper DH 015 PFK

E 09.644e

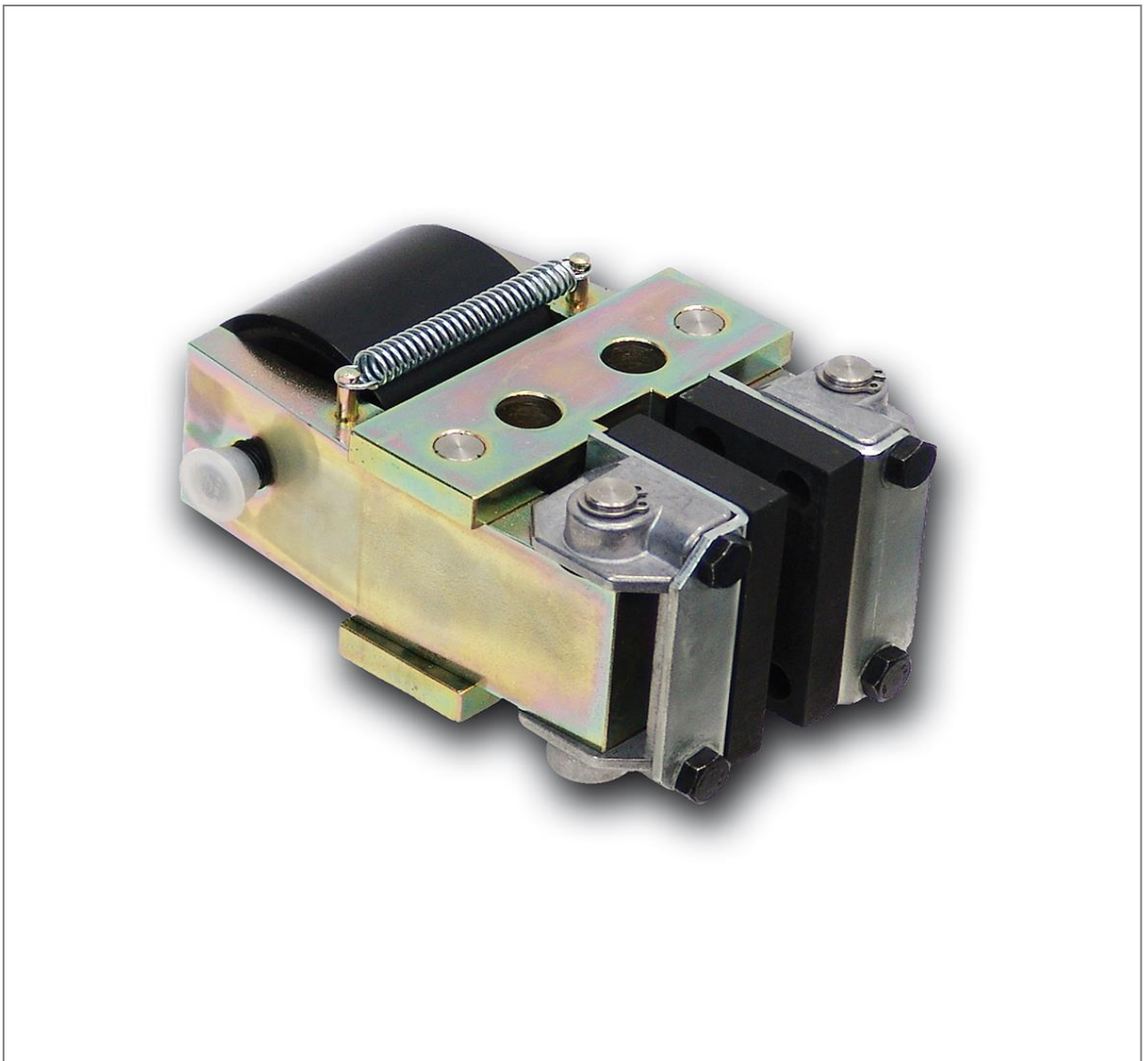

Any questions? Please contact us.

Morskate Aandrijvingen BV

Oosterveldsingel 47A
7558 PJ Hengelo (Ov)
The Netherlands

NL
T +31 (0)74 - 760 11 11
info@morskateaandrijvingen.nl
www.morskateaandrijvingen.nl

DE
T +49 692 - 222 34 95
info@morskateantriebstechnik.de
www.morskateantriebstechnik.de

EN
T +31 (0)74 - 760 11 11
info@morskatedrivetechnology.com
www.morskatedrivetechnology.com

RINGSPANN	Installation and Operating Instructions for Brake Caliper DH 015 PFK pneumatically activated – spring released			E 09.644e	
Date: 11.09.2013	Version : 6	drawn...: Su	checked: Su	Pages: 10	Page: 2

IMPORTANT

Please read these instructions carefully before installing and operating the product. Your particular attention is drawn to the notes on safety.

These installation and operating instructions are valid on condition that the product meets the selection criteria for its proper use. Selection and design of the product is not the subject of these installation and operating instructions.

Disregarding or misinterpreting these installation and operating instructions invalidates any product liability or warranty by RINGSPANN; the same applies if the product is taken apart or changed.

These installation and operating instructions should be kept in a safe place and should accompany the product if it is passed on to others – either on its own or as part of a machine – to make it accessible to the user.

SAFETY NOTICE

- Installation and operation of this product should only be carried out by skilled personnel.
- Repairs may only be carried out by the manufacturer or accredited RINGSPANN agents.
- If a malfunction is indicated, the product or the machine into which it is installed, should be stopped immediately and either RINGSPANN or an accredited RINGSPANN agent should be informed.
- Switch off the power supply before commencing work on electrical components.
- Rotating machine elements must be protected by the purchaser to prevent accidental contact.
- Supplies abroad are subject to the safety laws prevailing in those countries.

RINGSPANN	Installation and Operating Instructions for Brake Caliper DH 015 PFK pneumatically activated – spring released			E 09.644e	
	Date: 11.09.2013	Version : 6	drawn...: Su	checked: Su	Pages: 10 Page: 3

Contents

1. **General information**
2. **Configuration and function**
3. **Drawing and parts list**
4. **Condition on deliver**
5. **Installing the RINGSPANN brake caliper**
 - 5.1 Installation
 - 5.2 Compressed air connection
 - 5.3 Running-in procedure
6. **Maintenance**
 - 6.1 General maintenance
 - 6.2 Checking brake pad wear and replacement of brake pads
7. **Disassembling; exchange of the piston seal in the brake chamber**

RINGSPANN	Installation and Operating Instructions for Brake Caliper DH 015 PFK pneumatically activated – spring released			E 09.644e	
	Date: 11.09.2013	Version : 6	drawn...: Su	checked: Su	Pages: 10 Page: 4

1. General information

These installation and operating instructions apply to:

- the DH 015 PFK, brake caliper mounted at a right angle to the brake disc, see Fig. 3.1 in Section 3.
- for installation on a brake disc with a thickness of 12.5 mm.
- various types of brake-pads, e.g. with wear alarm cable, increased glide speed, double friction surface or other special brake pad materials.
- the part number 4457-150106-000000 (taper type lubrication nipple)

An identification plate with a 16-digit part number is affixed to the caliper. The precise design of the brake caliper is defined by this part number only.

Please consult the drawings in each section when using this instructions.

2. Configuration and function

The brake caliper is used as a stopping and parking brake.

Braking force is generated by compressed air. The brake is opened by spring force.

Rotating parts must be secured by the user against inadvertent contact (e.g. brake disc).



Danger to life and limb!

It is essential to secure the entire drive train against inadvertent starts during brake installation and maintenance. Rotating components can cause severe injuries.

Therefore, rotating components (e.g. brake disc) must be secured by the operator to prevent accidental contact.



Caution!

If the brakes are used as holding brakes, the braking torques can not be attained. Reductions up to 50% of the braking torques are possible.

3. Drawing and parts list

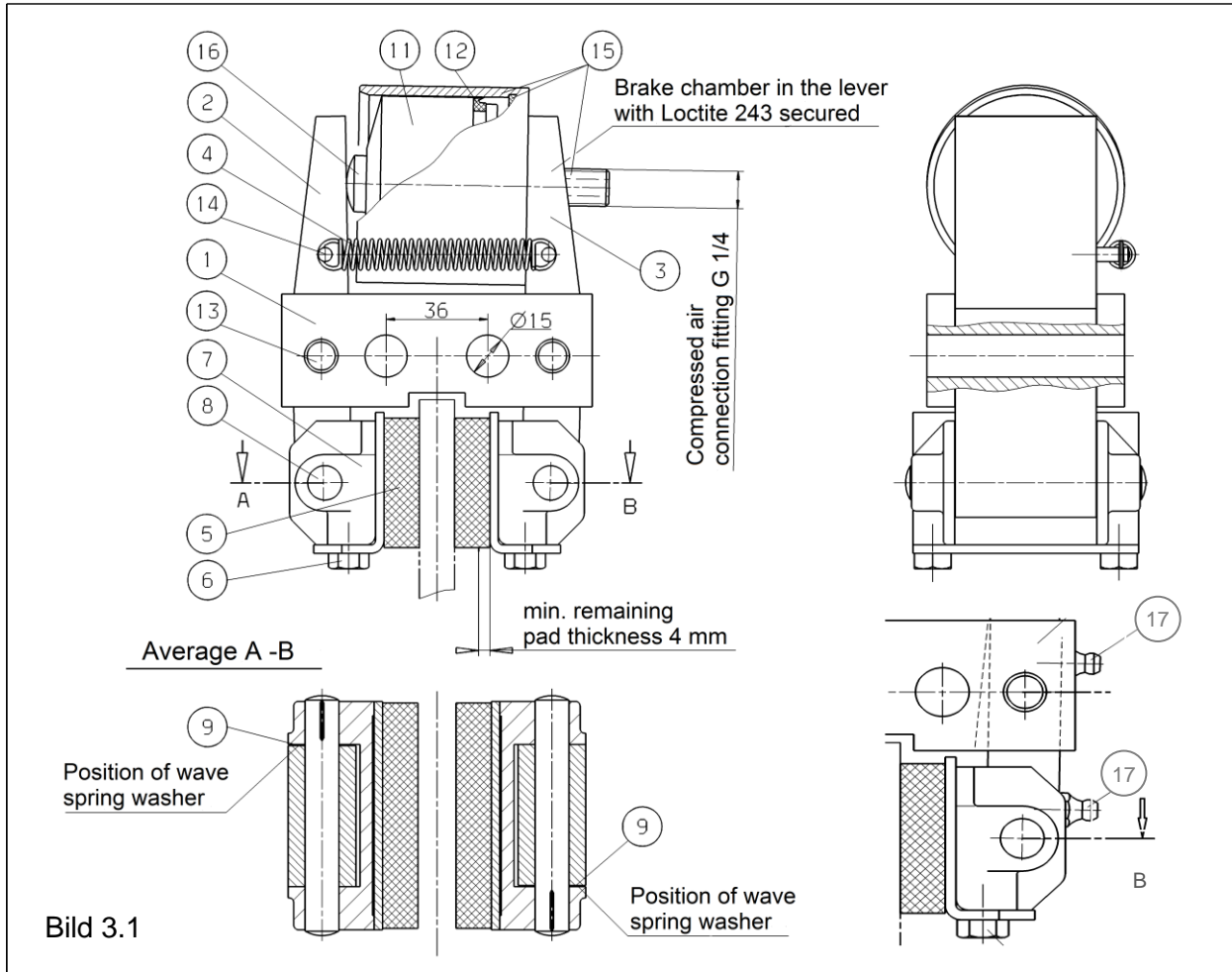

Parts list:

Part	Nomenclature	Quantity	Part number
1	Frame for DH 15 P	1	2475-110001-000000
2	Lever	1	2738-142001-000000
3	Lever for brake chamber	1	2738-142002-000000
4	Tension spring 10.0x47.0x1.25	1	2701-009023-000000
5	Standard brake pad for brake caliper: 4457-901117-000000	2	2472-005013-A00112*
	Brake pad from BK 5300 (v=50m/s) for brake caliper: 4457-901117-A00103	2	2472-005013-A00103*
	Brake pad with wear alarm cable for brake caliper: 4457-150107-000000	1	2472-005013-A00101**
	Brake pad from Teflon PTFE for brake caliper: 4457-901117-A00105	2	2472-005013-A00105*

RINGSPANN	Installation and Operating Instructions for Brake Caliper DH 015 PFK pneumatically activated – spring released			E 09.644e	
	Date: 11.09.2013	Version : 6	drawn...: Su	checked: Su	Pages: 10 Page: 6

6	Hexagon head screw M8x12 DIN EN ISO 4017	4	5019-008003-000000
7	Friction lining swivel part	2	2476-081001-000000
8	Grooved pin for friction lining swivel part	2	1517-000011-000000
9	Wave spring washer	2	5124-021001-000000
10	Brake chamber completely to DH 15 (Part 11, 12, 15 and 16)	1	3514-063100-000000
11	Piston	1	2742-063100-000000
12	Piston seal NAP 310 63x53x4,3	1	5116-054003-000000
13	Grooved pin for frame	2	2711-012623-000000
14	Grooved pin for tension spring	2	5236-005010-000000
15	Building group cylindrical tube	1	3514-065001-000000
16	Pushrod to DH 15	1	2721-020100-000000
17	taper type lubrication nipple M8x1 (only part number 4457-150106-000000)	4	5015-008007-000000

*) Part number for 1 brake pad * *) Part number for 1 set (2 pieces) brake pads

4. Condition on delivery

The brake caliper is delivered with a standard brake gap of 13.5 mm (brake disc thickness of 12.5 mm and a gap of 0.5 mm between the disc and each brake pad Pos. 5). The air connection G ¼ is locked with a protective cap..

5. Installing the RINGSPANN brake caliper

Before installing the brake, the brake disc must be cleaned with alcohol, e.g. ethyl or isopropyl alcohol, or a water-based surfactant solution (soapy water, etc.) and then rubbed dry with a clean cloth.

When cleaning the brake disc with a thinner, acetone or a brake cleaning agent, it is important to ensure that neither these cleaners nor any cleaner residues come in contact with the brake pads. This is especially important in the case of brakes used only as parking brakes, as no dynamic braking operations take place during which thinner residues would be rubbed off the brake disc.



Caution!

Oil and rust-proofing-agent residues reduced friction coefficient and thus diminish transmissible braking torque substantially!

5.1 Installation

The brake caliper should be mounted to stable, vibration-free machine components in order to ensure noise-free, non-screech.

During installation, it is essential to ensure that brake pads are centred and in full contact with the brake disc (the midlines of the brake arm must point to the midpoint of the brake disc.).

RINGSPANN	Installation and Operating Instructions for Brake Caliper DH 015 PFK pneumatically activated – spring released			E 09.644e	
	Date: 11.09.2013	Version : 6	drawn...: Su	checked: Su	Pages: 10 Page: 7

Maximum permissible lateral brake disc wobble is 0.2 mm. Greater wobble may cause rattling and shaking of the brake unit.

The brake caliper is mounted to the machine component with using 2 M14 bolts (strength class 8.8).

	<p>Caution!</p> <p>When assembling, make sure that the brake pads are centred aligned and in full contact with the brake disc. The maximum permissible wear is to observed .</p>
---	---

5.2 Compressed air connection

A flexible hose connection is required. Please use hoses with a diameter of 6 mm. Hose pressure must be at least 7 bar (preferably 12 bar) with a temperature range of approx. - 20°C to + 80°C.

Air hoses are connected to the brake chamber with a G ¼" fitting (Whitworth threaded pipe, DIN ISO 228-1).

The caliper must first be mounted onto the brake disc before air pressure is introduced.

Operating pressure may range between 1 to 6 bar, depending on braking force.

Compressed air must be filtered to remove all dirt, pipe chips, rust and condensation. Purified air must then be enriched with a fine oil mist injected by a standard, commercially available conditioning unit. The quantity of oil added depends on the nominal air flow rate in l/min and is specified by the manufacturer of the conditioning unit.

The following types of oil are recommended for conditioning units:

<u>Suitable types of oil</u>	<u>Viscosity at 20° C (mm²/s)</u>
Avia Avilub RSL 3	34
BP Energol HLP 40	27
ESSO Spinesso 34	23
Shell Tellus Öl C 10	22
Mobil VAC HLP 9	25,2

Maximum air consumption per braking operations is approx. 124 cm³ .

	<p>Caution!</p> <p>Check to ensure that the brake disc rotates freely.</p>
---	---

5.3 Running-in procedure

Optimum braking effect is achieved only when both brake pads (5) are in full contact with the brake disc and the brake pads have attained a temperature of approx. 200°C. This requires multiple, brief braking while the brake disc is rotating (run-in). Multiple brief braking actions under low pressure (1 to 2 bar) while the brake disc is rotating are required.

RINGSPANN	Installation and Operating Instructions for Brake Caliper DH 015 PFK pneumatically activated – spring released			E 09.644e	
	Date: 11.09.2013	Version : 6	drawn...: Su	checked: Su	Pages: 10 Page: 8



Caution!

If running-in cannot be performed, the braking torques specified in our catalog no. 46 cannot be achieved. Reductions of up to 50% are possible.

6. Maintenance

Maintenance should be performed on the brake calliper at intervals of 4 to 12 weeks, depending upon the frequency and duration of operation.

6.1 General maintenance

- Check both brake caliper lever arms for ease from movement.
- Clean all bearings and glide points
- Lubricate all bearing and glide points.



Caution!

Brake pads must not come in contact with lubricants.

Check for tight bolt / screw connections:

- brake caliper to machine component
- brake chamber to brake lever
- brake pads to the swing parts on the brake lever

Check the following for proper seal / leaks:

- brake chamber
- hose connection and connection to the brake chamber

(leaks can for example be determined easily and quickly with a commercial "leak searcher").

For part number 4457-150106-000000

Check both brake caliper lever arms and the friction lining swivel parts for ease from movement. Clean all bearing and sliding points and lubricate via the taper type lubrication nipple. Brake pads must not come in contact with lubricants.

The type of grease and lubrication intervals are defined by the machine manufacturer, depending on the machine and the environmental influences.

Also, the initial lubrication is made by the machine manufacturer.

6.2 Checking brake pad wear and replacement of brake pads

Brake pad material must have a thickness of at least 4 mm (from the top surface of the brake pad to the top surface of the steel mounting plate) (see Fig. 3.1 in Section 3). Brake pads or

RINGSPANN	Installation and Operating Instructions for Brake Caliper DH 015 PFK pneumatically activated – spring released			E 09.644e	
	Date: 11.09.2013	Version : 6	drawn...: Su	checked: Su	Pages: 10 Page: 9

brake linings (Pos. 5) must always be replaced in pairs. For unscrewing and screwing on fixed spanners or ring spanners with SW 13 are needed.



Danger to life and limb!

Brake pads may only be replacing when the plant or the working machine is at complete standstill!



Caution!

Brake pads or brake linings must always be replaced in pairs.

7. Disassembling; exchange of the piston seal in the brake chamber

The brake chamber is defective if the pushrod Pos. 16 (Fig. 3.1) does not move when compressed air is applied and released or when air escapes from the brake chamber. The brake chamber should be overhauled by the manufacturer. If this is not possible the procedure described should be followed:

- Remove the entire brake caliper from the machine component by loosening the screws.
- Disconnect the tension spring (4).
- Remove the grooved pin (13) with which the lever (2) is fastened in the frame by pressing it from the frame in the direction of the groove. Set the lever (2) aside (see Fig. 7.1).
- Press the pressure piston (11) with the pushrod (16) and piston seal (12) through the G ¼ air supply bore and out of the cylindrical tube (15), using a drift punch or rod with a diameter of 5 mm.
- Replace the worn piston seal (12).
- Clean the individual parts before reassembling and coat the inside wall thinly with Alvanina grease G2 (manufactured by Shell).
- Push the pressure piston unit into the cylindrical tube to the stop on the bottom.
- Reinstall the lever (2) with a new grooved pin (13). Make sure that you insert the grooved pin opposite to its original position so that the groove fits into the previously tension-free bore.
- Replace the tension spring.

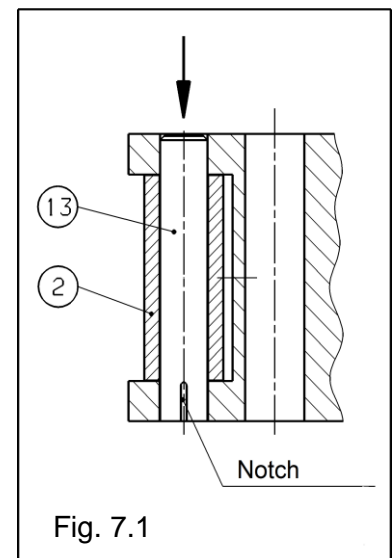

RINGSPANN	Installation and Operating Instructions for Brake Caliper DH 015 PFK pneumatically activated – spring released			E 09.644e	
	Date: 11.09.2013	Version : 6	drawn...: Su	checked: Su	Pages: 10 Page: 10



Danger to life and limb!

When disassembling the brake It is essential to secure the entire drive train protected against accidental activation. Rotating components can cause severe injuries.

Therefore, rotating components (e.g. brake disc) must be secured by the operator to prevent accidental contact



Caution!

Secure the brake for dismantling.